



## CHAPTER 25

# IPv6

This chapter provides information and commands concerning the following topics:

- Assigning IPv6 addresses to interfaces
- IPv6 and RIPng
- Configuration example: IPv6 RIP
- IPv6 tunnels: manual overlay tunnel
- Static routes in IPv6
- Floating static routes in IPv6
- Verifying and troubleshooting IPv6
- IPv6 ping

**NOTE:** For an excellent overview of IPv6, I strongly recommend you read Jeff Doyle's book, *Routing TCP/IP Volume I*, Second Edition.

### Assigning IPv6 Addresses to Interfaces

Router(config)# <b>ipv6 unicast-routing</b>	Enables the forwarding of IPv6 unicast datagrams globally on the router.
Router(config)# <b>interface fastethernet 0/0</b>	Moves to interface configuration mode.
Router(config-if)# <b>ipv6 enable</b>	Automatically configures an IPv6 link-local address on the interface and enables IPv6 processing on the interface.
	<b>NOTE:</b> The link-local address that the <b>ipv6 enable</b> command configures can be used only to communicate with nodes on the same link.
Router(config-if)# <b>ipv6 address 3000::1/64</b>	Configures a global IPv6 address on the interface and enables IPv6 processing on the interface.
Router(config-if)# <b>ipv6 address 2001:db8:0:1::/64 eui-64</b>	Configures a global IPv6 address with an interface identifier in the low-order 64 bits of the IPv6 address.

Router(config-if)# <b>ipv6 address fe80::260:3eff:fe47:1530/64 link-local</b>	Configures a specific link-local IPv6 address on the interface instead of the one that is automatically configured when IPv6 is enabled on the interface.
Router(config-if)# <b>ipv6 unnumbered type/number</b>	Specifies an unnumbered interface and enables IPv6 processing on the interface. The global IPv6 address of the interface specified by <i>type/number</i> will be used as the source address.

### IPv6 and RIPng

Router(config)# <b>interface serial 0/0</b>	Moves to interface configuration mode.
Router(config-if)# <b>ipv6 rip tower enable</b>	Creates the RIPng process named tower and enables RIPng on the interface.
	<b>NOTE:</b> Unlike RIPv1 and RIPv2, where you needed to create the RIP routing process with the <b>router rip</b> command and then use the <b>network</b> command to specify the interfaces on which to run RIP, the RIPng process is created automatically when RIPng is enabled on an interface with the <b>ipv6 rip name enable</b> command.
	<b>NOTE:</b> Cisco IOS Software automatically creates an entry in the configuration for the RIPng routing process when it is enabled on an interface.
	<b>NOTE:</b> The <b>ipv6 router rip process-name</b> command is still needed when configuring optional features of RIPng.
Router(config)# <b>ipv6 router rip tower</b>	Creates the RIPng process named tower if it has not already been created, and moves to router configuration mode
Router(config-router)# <b>maximum-paths 2</b>	Defines the maximum number of equal-cost routes that RIPng can support.
	<b>NOTE:</b> The number of paths that can be used is a number from 1 to 64. The default is 4.

### Configuration Example: IPv6 RIP

Figure 25-1 illustrates the network topology for the configuration that follows, which shows how to configure IPv6 and RIPng using the commands covered in this chapter.

Figure 25-1 Network Topology for IPv6/RIPng Configuration Example

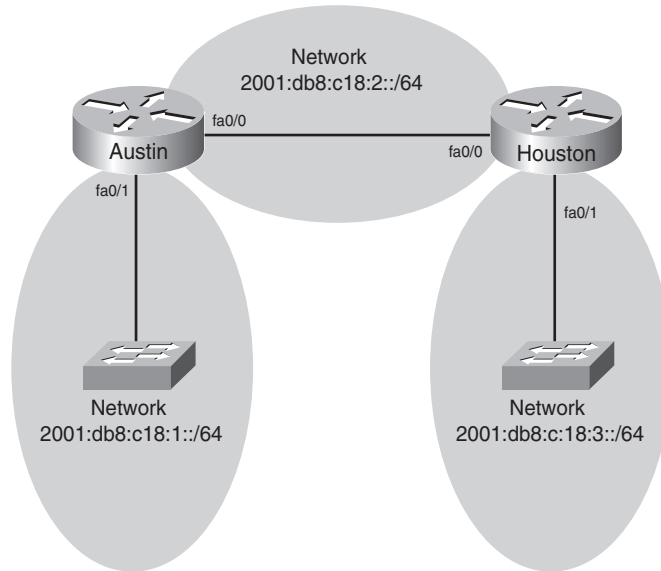

Austin Router

Router> <b>enable</b>	Moves to privileged mode
Router# <b>configure terminal</b>	Moves to global configuration mode
Router(config)# <b>hostname Austin</b>	Assigns a host name to the router
Austin(config)# <b>ipv6 unicast-routing</b>	Enables the forwarding of IPv6 unicast datagrams globally on the router
Austin(config)# <b>interface fastethernet 0/0</b>	Enters interface configuration mode
Austin(config-if)# <b>ipv6 enable</b>	Automatically configures an IPv6 link-local address on the interface and enables IPv6 processing on the interface
Austin(config-if)# <b>ipv6 address 2001:db8:c18:2::/64 eui-64</b>	Configures a global IPv6 address with an interface identifier in the low-order 64 bits of the IPv6 address

Austin(config-if)# <b>ipv6 rip tower enable</b>	Creates the RIPng process named tower and enables RIPng on the interface
Austin(config-if)# <b>no shutdown</b>	Activates the interface
Austin(config-if)# <b>interface fastethernet 0/1</b>	Enters interface configuration mode
Austin(config-if)# <b>ipv6 enable</b>	Automatically configures an IPv6 link-local address on the interface and enables IPv6 processing on the interface
Austin(config-if)# <b>ipv6 address 2001:db8:c18:1::/64 eui-64</b>	Configures a global IPv6 address with an interface identifier in the low-order 64 bits of the IPv6 address
Austin(config-if)# <b>ipv6 rip tower enable</b>	Creates the RIPng process named tower and enables RIPng on the interface
Austin(config-if)# <b>no shutdown</b>	Activates the interface
Austin(config-if)# <b>exit</b>	Moves to global configuration mode
Austin(config)# <b>exit</b>	Moves to privileged mode
Austin# <b>copy running-config startup-config</b>	Saves the configuration to NVRAM

## Houston Router

Router> <b>enable</b>	Moves to privileged mode
Router# <b>configure terminal</b>	Moves to global configuration mode
Router(config)# <b>hostname Houston</b>	Assigns a host name to the router
Houston(config)# <b>ipv6 unicast-routing</b>	Enables the forwarding of IPv6 unicast datagrams globally on the router
Houston(config)# <b>interface fastethernet 0/0</b>	Enters interface configuration mode
Houston(config-if)# <b>ipv6 enable</b>	Automatically configures an IPv6 link-local address on the interface and enables IPv6 processing on the interface
Houston(config-if)# <b>ipv6 address 2001:db8:c18:2::/64 eui-64</b>	Configures a global IPv6 address with an interface identifier in the low-order 64 bits of the IPv6 address
Houston(config-if)# <b>ipv6 rip tower enable</b>	Creates the RIPng process named tower and enables RIPng on the interface

Houston(config-if)# <b>no shutdown</b>	Activates the interface
Houston(config-if)# <b>interface fastethernet 0/1</b>	Enters interface configuration mode
Houston(config-if)# <b>ipv6 enable</b>	Automatically configures an IPv6 link-local address on the interface and enables IPv6 processing on the interface
Houston(config-if)# <b>ipv6 address 2001:db8:c18:3::/64 eui-64</b>	Configures a global IPv6 address with an interface identifier in the low-order 64 bits of the IPv6 address
Houston(config-if)# <b>ipv6 rip tower enable</b>	Creates the RIPng process named tower and enables RIPng on the interface
Houston(config-if)# <b>no shutdown</b>	Activates the interface
Houston(config-if)# <b>exit</b>	Moves to global configuration mode
Houston(config)# <b>exit</b>	Moves to privileged mode
Houston# <b>copy running-config startup-config</b>	Saves the configuration to NVRAM

## IPv6 Tunnels: Manual Overlay Tunnel

**NOTE:** Although not part of the official CCNA exam objectives, the concept of IPv6 tunnels is one that network administrators dealing with IPv6 need to be comfortable with.

Figure 25-2 illustrates the network topology for the configuration that follows, which shows how IPv6 tunnels are created.

Figure 25-2 Network Topology for IPv6 Tunnel Creation

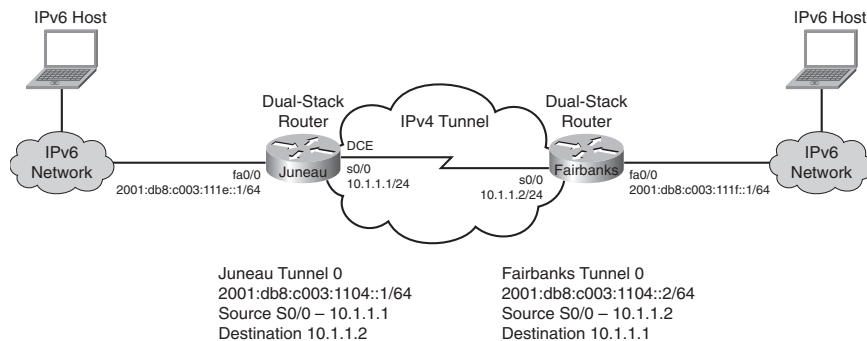

## Juneau Router

Router> <b>enable</b>	Moves to privileged mode
Router# <b>configure terminal</b>	Moves to global configuration mode
Router(config)# <b>hostname Juneau</b>	Sets the host name of the router
Juneau(config)# <b>ipv6 unicast-routing</b>	Enables the forwarding of IPv6 unicast datagrams globally on the router
Juneau(config)# <b>interface tunnel0</b>	Moves to tunnel interface configuration mode
Juneau(config-if)# <b>ipv6 address 2001:db8:c003:1104::1/64</b>	Assigns an IPv6 address to this interface
Juneau(config-if)# <b>tunnel source serial 0/0</b>	Specifies the source interface type and number for the tunnel interface
Juneau(config-if)# <b>tunnel destination 10.1.1.2</b>	Specifies the destination IPv4 address for the tunnel interface
Juneau(config-if)# <b>tunnel mode ipv6ip</b>	Defines a manual IPv6 tunnel; specifically, that IPv6 is the passenger protocol and IPv4 is both the encapsulation and protocol for the IPv6 tunnel
Juneau(config-if)# <b>interface fastethernet 0/0</b>	Moves to interface configuration mode
Juneau(config-if)# <b>ipv6 address 2001:db8:c003:111e::1/64</b>	Assigns an IPv6 address to this interface
Juneau(config-if)# <b>no shutdown</b>	Activates the interface
Juneau(config-if)# <b>interface serial 0/0</b>	Moves to interface configuration mode
Juneau(config-if)# <b>ip address 10.1.1.1 255.255.255.252</b>	Assigns an IPv4 address and netmask
Juneau(config-if)# <b>clock rate 56000</b>	Sets the clock rate on interface
Juneau(config-if)# <b>no shutdown</b>	Starts the interface
Juneau(config-if)# <b>exit</b>	Moves to global configuration mode
Juneau(config)# <b>exit</b>	Moves to privileged mode
Juneau# <b>copy running-config startup-config</b>	Saves the configuration to NVRAM

## Fairbanks Router

Router> <b>enable</b>	Moves to privileged mode
Router# <b>configure terminal</b>	Moves to global configuration mode
Router(config)# <b>hostname Fairbanks</b>	Sets the host name of the router
Fairbanks(config)# <b>interface tunnel0</b>	Moves to tunnel interface configuration mode
Fairbanks(config-if)# <b>ipv6 address 2001:db8:c003:1104::2/64</b>	Assigns an IPv6 address to this interface
Fairbanks(config-if)# <b>tunnel source serial 0/0</b>	Specifies the source interface type and number for the tunnel interface
Fairbanks(config-if)# <b>tunnel destination 10.1.1.1</b>	Specifies the destination IPv4 address for the tunnel interface
Fairbanks(config-if)# <b>tunnel mode ipv6ip</b>	Defines a manual IPv6 tunnel; specifically, that IPv6 is the passenger protocol and IPv4 is both the encapsulation and protocol for the IPv6 tunnel
Fairbanks(config-if)# <b>interface fastethernet 0/0</b>	Moves to interface configuration mode
Fairbanks(config-if)# <b>ipv6 address 2001:db8:c003:111f::1/64</b>	Assigns an IPv6 address to this interface
Fairbanks(config-if)# <b>no shutdown</b>	Activates the interface
Fairbanks(config-if)# <b>interface serial 0/0</b>	Moves to interface configuration mode
Fairbanks(config-if)# <b>ip address 10.1.1.2 255.255.255.252</b>	Assigns an IPv4 address and netmask
Fairbanks(config-if)# <b>no shutdown</b>	Starts the interface
Fairbanks(config-if)# <b>exit</b>	Moves to global configuration mode
Fairbanks(config)# <b>exit</b>	Moves to privileged mode
Fairbanks# <b>copy running-config startup-config</b>	Saves the configuration to NVRAM

## Static Routes in IPv6

**NOTE:** Although not part of the CCNA exam objectives, the concept of static routes in IPv6 is one that network administrators dealing with IPv6 need to be comfortable with.

**NOTE:** To create a static route in IPv6, you use the same format as creating a static route in IPv4.

Figure 25-3 illustrates the network topology for the configuration that follows, which shows how to configure static routes with IPv6. Note that only the static routes on the Austin router are displayed.

Figure 25-3 Network Topology for IPv6 Static Route Configuration

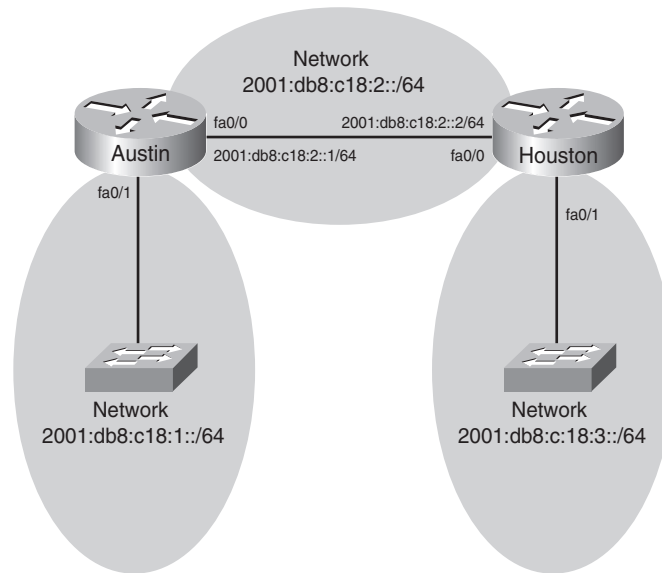

Austin(config)# <b>ipv6 route</b> <b>2001:db8:c18:3::/64</b> <b>2001:db8:c18:2::2/64</b>	Creates a static route configured to send all packets to a next-hop address of 2001:db8:c18:2::2
Austin(config)# <b>ipv6 route</b> <b>2001:db8:c18:3::/64 fastethernet</b> <b>0/0</b>	Creates a directly attached static route configured to send packets out interface fastethernet 0/0
Austin(config)# <b>ipv6 route</b> <b>2001:db8:c18:3::/64 fastethernet</b> <b>0/0 2001:db8:c18:2::2</b>	Creates a fully specified static route on a broadcast interface



## Floating Static Routes in IPv6

**NOTE:** Although not part of the CCNA exam objectives, the concept of floating static routes in IPv6 is one that network administrators dealing with IPv6 need to be comfortable with.

To create a static route with an administrative distance (AD) set to 200, as opposed the default AD of one (1), enter the following command, for example:

```
Austin(config)# ipv6 route 2001:db8:c18:3::/64 fastethernet 0/0 200
```

The default ADs used in IPv4 are the same for IPv6.

## Verifying and Troubleshooting IPv6

**CAUTION:** Using the **debug** command may severely affect router performance and might even cause the router to reboot. Always exercise caution when using the **debug** command. Do not leave **debug** on. Use it long enough to gather needed information, and then disable debugging with the **undebug all** command.

**TIP:** Send your **debug** output to a syslog server to ensure you have a copy of it in case your router is overloaded and needs to reboot.

Router# <b>clear ipv6 rip</b>	Deletes routes from the IPv6 RIP routing table and, if installed, routes in the IPv6 routing table
Router# <b>clear ipv6 route *</b>	Deletes all routes from the IPv6 routing table
	<b>NOTE:</b> Clearing all routes from the routing table will cause high CPU utilization rates as the routing table is rebuilt.
Router# <b>clear ipv6 route 2001:db8:c18:3::/64</b>	Clears this specific route from the IPv6 routing table.
Router# <b>clear ipv6 traffic</b>	Resets IPv6 traffic counters.
Router# <b>debug ipv6 packet</b>	Displays debug messages for IPv6 packets.
Router# <b>debug ipv6 rip</b>	Displays debug messages for IPv6 RIP routing transactions.

---

Router# <b>debug ipv6 routing</b>	Displays debug messages for IPv6 routing table updates and route cache updates.
Router# <b>show ipv6 interface</b>	Displays the status of interfaces configured for IPv6.
Router# <b>show ipv6 interface brief</b>	Displays a summarized status of interfaces configured for IPv6.
Router# <b>show ipv6 neighbors</b>	Displays IPv6 neighbor discovery cache information.
Router# <b>show ipv6 protocols</b>	Displays the parameters and current state of the active IPv6 routing protocol processes.
Router# <b>show ipv6 rip</b>	Displays information about the current IPv6 RIP process.
Router# <b>show ipv6 route</b>	Displays the current IPv6 routing table.
Router# <b>show ipv6 route summary</b>	Displays a summarized form of the current IPv6 routing table.
Router# <b>show ipv6 routers</b>	Displays IPv6 router advertisement information received from other routers.
Router# <b>show ipv6 static</b>	Displays only static IPv6 routes installed in the routing table.
Router# <b>show ipv6 static 2001:db8:5555:0/16</b>	Displays only static route information about the specific address given.
Router# <b>show ipv6 static interface serial 0/0</b>	Displays only static route information with the specified interface as the outgoing interface.
Router# <b>show ipv6 static detail</b>	Displays a more detailed entry for IPv6 static routes.
Router# <b>show ipv6 traffic</b>	Displays statistics about IPv6 traffic.
Router# <b>show ipv6 tunnel</b>	Displays IPv6 tunnel information.

## IPv6 Ping

To diagnose basic network connectivity using IPv6 to the specified address, enter the following command:

```
Router#ping ipv6 2001:db8::3/64
```

The following characters can be displayed as output when using PING in IPv6.

Character	Description
!	Each exclamation point indicates receipt of a reply.
.	Each period indicates that the network server timed out while waiting for a reply.
?	Unknown error.
@	Unreachable for unknown reason.
A	Administratively unreachable. Usually means that an access control list (ACL) is blocking traffic.
B	Packet too big.
H	Host unreachable.
N	Network unreachable (beyond scope).
P	Port unreachable.
R	Parameter problem.
T	Time exceeded.
U	No route to host.